

## SA SELECTORIZED SERIES

## SA001 - CHEST PRESS



## PRODUCT OVERVIEW

A professional-grade chest training solution representing exceptional value! The machine's movement pattern perfectly matches shoulder joint trajectories for complete range of motion and thorough muscle activation. The clever combination of horizontal and hammer grip handles enables precise targeting of different chest regions. The seat features a quick-adjustment system for effortless positioning.

# SPECIFICATIONS & KEY FEATURES

## Specifications

Dimension:	1290*953*1566mm
Total Weight:	192kg
Weight Stack:	100kg
Max Weight Stack:	125kg

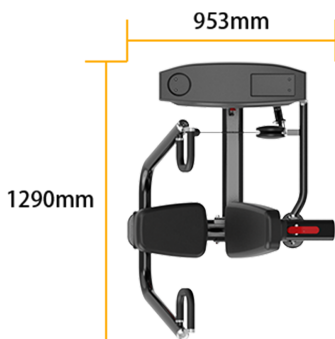

## Product Features

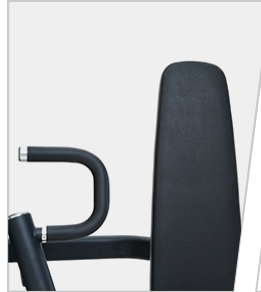

### Dual-Handle Design, Comprehensive Training

The dual-handle design exemplifies ergonomic excellence. Horizontal handles focus on overall pectoral muscle development, while hammer grips emphasize inner chest engagement, maximizing mid-line muscle activation. The machine's movement pattern perfectly aligns with shoulder joint mechanics, effectively reducing shoulder injury risk while maximizing training efficiency.



### Smooth Seat Adjustment, Effortless Position Customization

The ergonomic seat features 5-position adjustment, making position changes effortless. This user-centric design allows every trainee to quickly find their optimal training position, enjoying a professional-grade comfortable training experience.



### Adjustable Backrest, Maximizing Every Contraction

The backrest offers 6-position front/back adjustment, ensuring optimal support for users of all body types. Additionally, the backrest's adjustment mechanism allows you to fine-tune your seated press movement range, focusing on different power phases for a more refined training experience.



### Precision Weight Stack Engineering, Refined Power Control

Utilizing a high-density cast iron weight stack system with specialized black textured powder coating for premium feel. Special protective coating ensures wear and corrosion resistance, providing lasting durability for professional training. The weight distribution is precisely calibrated, allowing you to easily find that "perfect training weight" without compromising.